

# 2-Stage Electronic Unit Heater KB ECO2S+ Series



### Model Code:

KB 24 04 -1 -ECO2S-PLUS  
A B C D E

A: Series  
B: 20 - 208V, 24 - 240/208V  
C: kiloWatts ( 4 - 15 )  
D: -1 = Single Phase  
E: ECO2S-PLUS = Electronic Control + Remote Sensor



- ECO2S+ electronic temperature controller
- Energy efficient 2-stage heating
- Includes ECO2S+ remote temperature sensor
- Built-In provision for optional 24V remote thermostat
- Compatible with NEST / any 24V WIFI Stat
- Remote control included
- Large LED display
- Standard color: textured gray
- Fan Delay, Fan Only & timer modes
- Unit bearing motor
- Adjustable louvers
- Spiral finned heat elements
- Universal bracket included
- Patented Smart Limit® Protection
- 5-year limited warranty

## ECO2S+ 2-Stage Electronic Garage Heater with IR Remote Control

The ECO2S+ KB series unit heaters offers unparalleled performance, energy efficiency and user control by incorporating another King innovation, the in-built ECO2S+ electronic thermostat with remote control. Offering energy efficient 2-stage heating, with Eco mode that automatically uses the lowest wattage needed to heat the room, integrated fan only and timer modes, as well as a remote control for simple operation. With the ECO2S+ Remote Temperature Sensor, your ECO2S+ heater knows exactly where the room's cold spot is and works smarter to keep the entire room comfortable. Just place it on a wall or shelf and get the right temperature, right where you want it. Comes standard with a provision for adding an optional 24V thermostat for remote temperature control. Combined with integrated summer fan only and thermostat timer modes, the KB ECO2S+ has you covered....Designed for use as primary or supplemental heat sources in warehouses, stores or large garages spaces. Spiral steel elements and high CFM ensure even air distribution producing cooler element operation which prolongs the life of the heater. By combining the highest quality components, with a dynamically balanced fan blade, the KB ECO2S+ unit heater will provide years of trouble-free service and keep heating bills to a minimum. Includes universal wall/ceiling bracket for simple installation.

### ECO2S+ Electronic Controller Features:

- Electronic control for accuracy
- Energy-saving automatic 2-stage heating
- Large LED display
- Remote control and wall bracket included
- Thermostat timer mode (1-9 Hours)
- Fan Only mode
- Built-In fan delay
- Built-In provision for optional 24V remote thermostat
- Compatible with NEST / any 24V WIFI Stat

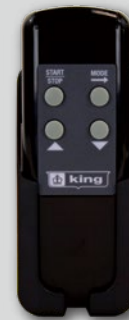

or Any 24V  
WIFI Stat

### Meet the **eco2S+** Sensor



Balanced Heat  
Throughout the Space



Comfort, Right  
Where You Want It



Remote  
Temperature Sensing

# 2-Stage Electronic Unit Heater KB ECO2S+ Series

## Ordering Information - single phase

MODEL	UPC	KW	BTUH	PHASE	VOLTS	AMPS	MOTOR HP	CFM	TEMP. RISE	AIR THROW	MAX. MOUNT HEIGHT	*SIZE	WT. (lbs.)
KB2404-1-ECO2S-PLUS	33237	4	13.5	1	240/208*	16.6/14.4	9W	400	38°F	15ft.	8ft.	B	36
KB2004-1-ECO2S-PLUS	33236	4	13.5	1	208	19.2	9W	400	38°F	15ft.	8ft.	B	36
KB2405-1-ECO2S-PLUS	33239	5	17	1	240/208*	20.8/18.0	9W	400	40°F	16ft.	8ft.	B	36
KB2005-1-ECO2S-PLUS	33238	5	17	1	208	24.0	9W	400	40°F	16ft.	8ft.	B	36
KB2407-1-ECO2S-PLUS	33241	7.5	25.6	1	240/208*	31.2/27.0	16W	600	40°F	20ft.	9ft.	B	36
KB2007-1-ECO2S-PLUS	33240	7.5	25.6	1	208	36.1	16W	600	40°F	20ft.	9ft.	B	29
KB2410-1-ECO2S-PLUS	33243	10	34.1	1	240/208*	41.6/36.1	25W	725	44°F	24ft.	10ft.	B	42
KB2010-1-ECO2S-PLUS	33242	10	34.1	1	208	48.1	25W	725	44°F	24ft.	10ft.	B	42
KB2412-1-ECO2S-PLUS-FB	33245	12.5	42.7	1	240/208*	52.1/45.1	35W	825	48°F	30ft.	11ft.	C	46
KB2012-1-ECO2S-PLUS-FB	33244	12.5	42.7	1	208	60.1	35W	825	48°F	30ft.	11ft.	C	46
KB2415-1-ECO2S-PLUS-FB	33247	15	51.2	1	240/208*	62.5/54.1	50W	925	51°F	33ft.	12ft.	C	47
KB2015-1-ECO2S-PLUS-FB	33246	15	51.2	1	208	72.1	50W	925	51°F	33ft.	12ft.	C	47

Maximum mounting height is manufacturer's recommendation

\*Dual rated heaters will draw 13% less amps and 25% less wattage when operated at 208V.

## Replacement Accessories

MODEL	UPC	DESCRIPTION	WT. (lbs.)
ECO2S-REMOTE	33489	ECO2S+ Replacement Infrared Remote Control	0.1
ECO2S-REMOTE-BRACKET	33490	ECO2S+ Replacement Infrared Remote Control Wall Mount Bracket	0.2
ECO2S-REMOTE-SENSOR	33491	ECO2S+ Remote Temperature Sensor	0.2
ECO2S-5V-PWRSPLY	33167	ECO2S+ 5V DC WALL ADAPTER, Optional Accessory	0.4

## Bracket Selection Chart

BRACKET #	HEATER KW SIZE USED WITH	BRACKET DIMENSIONS											
		L	W	H	A	B	C	D	E	F	X	Y	Z
KBB-2	4 to 15 kW (1 phase)	16 <sup>7</sup> / <sub>8</sub> "	2 <sup>15</sup> / <sub>16</sub> "	10 <sup>1</sup> / <sub>8</sub> "	1 <sup>1</sup> / <sub>4</sub> "	7"	1 <sup>7</sup> / <sub>8</sub> "	1 <sup>5</sup> / <sub>8</sub> "	13 <sup>5</sup> / <sub>8</sub> "	1 <sup>5</sup> / <sub>8</sub> "	¾"	1"	1 <sup>1</sup> / <sub>2</sub> "

## Engineering Specifications

Contractor shall supply and install KB ECO2S+ Series garage heaters manufactured by King Electrical Mfg. Company.

Heaters shall be of the wattage and voltage as indicated on the plans.

**Construction:** All exterior and interior metal enclosure parts are made from 20 gauge electrogalvanized Steel with a rust inhibiting baked enamel finish. Smooth rounded corners and protective edge trim give an attractive modern appearance.

**Adjustable Outlet Louver:** Louvers direct air up or down as needed for the heating application. Rear Intake Screen: Heavy gauge steel screen protects against foreign objects making accidental contact with the rotating fan blade.

**Spiral Fin Elements:** The metal sheath element is copper brazed with spiral fins then molded into a coil configuration. This combination produces the best heat transfer while eliminating the potential for hot spots by positioning the element in the maximum airflow stream.

**Totally Enclosed Fan Motor:** Permanently lubricated long life unit bearing motor with 20cc of oil. Epoxy-coated motor with enclosed rotor resists moisture and corrosion for long-lasting, trouble-free operation.

**Aluminum Fan Blade:** 5 blade fan mounted directly to the motor shaft for maximum efficiency.

**Auto-Reset Thermal Cutout:** Power is disconnected from the element if an overheated condition occurs. The fan continues to run to dissipate excess heat from the element. The element is re-energized automatically when the normal operating temperature returns.

**ECO2S+ Electronic Control:** Up, Down temperature mode. Automatic 2-Stage heating (High & ECO Modes). Start/Stop. Fan Only and Timer (1-9hours) Modes. Standard on all heaters.

**ECO2S+ Remote Temperature Sensor:** Wireless remote temperature sensing for balanced heating at the coldest spot in the room. 2.4G wireless protocol. Includes wall mounting bracket.

**Provision For 24V Remote Thermostat:** Includes terminals to connect an optional 24V 2-Stage Thermostat. Compatible with NEST / any 24V WIFI Stat.

**Easy Installation:** A quick access panel located on the bottom of the heater allows for quick wiring and easy maintenance for the life of the heater. Includes universal wall/ceiling bracket for simple installation.

**Approvals:** cULus (E41422)

# 2-Stage Electronic Unit Heater KB ECO2S+ Series

## Dimensional Data

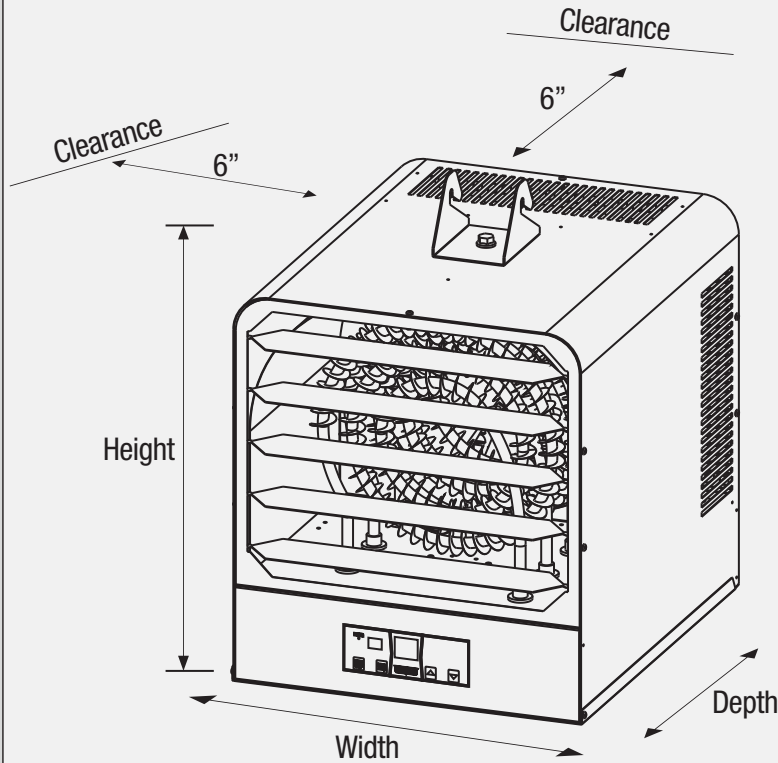

### • KBB-2 Wall/Ceiling Bracket Included

Garage heater brackets can be used for mounting on ceiling or wall. 3/8" threaded hole on top of unit heater can also be used with threaded rod to drop the unit closer to the floor.

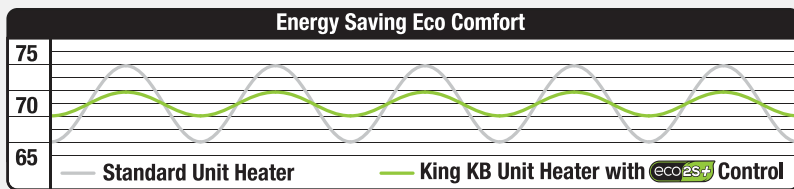
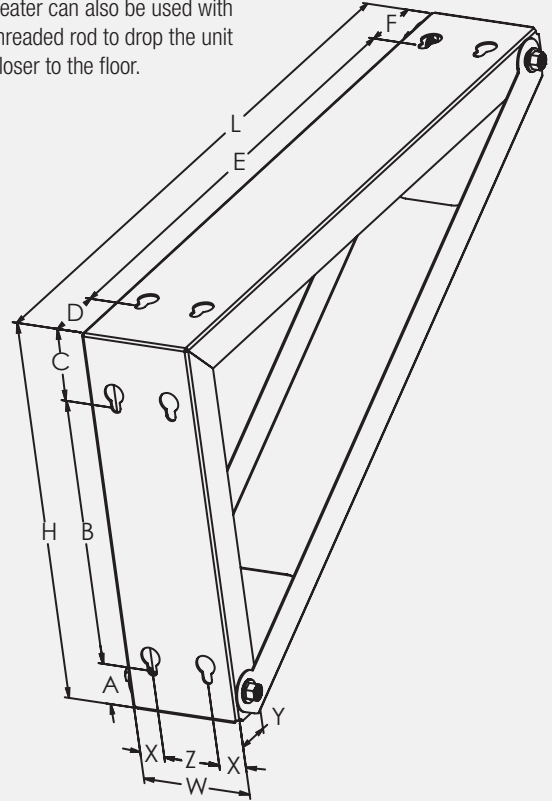

\*Reduces temperature swings

HEATER SIZE	HEIGHT	DEPTH	WIDTH
B	16.5"	13.5"	15"
C	16.5"	18"	15"